

MODEL 451

PRECISION LVDT CONDITIONER



FEATURES

- Calibrated Performance Without CAL Lab Testing
- Front-Panel Display of Voltage and Actual Displacement in mils, mm, or degrees
- Precision Digital Processor Design
- Calibration of Transducer and Conditioner While Installed
- Autozero on Command
- Three Modes of Operation: Example, Scale, and Gain
- LVDT* and RVDT* Operation
- Operates as a Carrier Amplifier for Bridge Transducers
- Designed for Poor Environments
- Measurement of an LVDT's or RVDT's Sensitivity Constant

The Ectron Model 451 is a unique advance in conditioners for LVDT* and RVDT* transducers. For the first time, the conditioner can be calibrated to the transducer without using a costly and time-consuming laboratory procedure. And autozero can be commanded at any time. Plus, the Model 451's display indicates the analog output voltage and actual transducer displacement in real time!



Actual Displacement Alternates with Output Voltage

* LVDT—Linear Variable Differential Transformer
* RVDT—Rotary Variable Differential Transformer

GENERAL DESCRIPTION

The Model 451 excites the transducer according to user set parameters for voltage and frequency. A variable gain differential amplifier receives the resulting signal which is then coupled to a synchronous detector, user controlled four-step filter, analog-to-digital converter, and micro-controller. Here, all functions from arithmetic calculations, to front-panel data and menu displays, to user interface operations are controlled. In parallel, the displacement data is calculated and coupled to the front panel for display. Finally, a digital-to-analog converter and output analog stages produce the desired analog output signal. The display indicates both the analog voltage and the actual transducer displacement. Settings, maintained in non-volatile memory, are entered into the Model 451 using the front panel controls.

OPERATING MODES

Example Mode

Mount the LVDT; then position the apparatus under test to one position of its motion (usually one extreme) and command the Model 451 to "capture" Point 1. Repeat with a second position to "capture" Point 2. Then key in the desired output voltages corresponding to the two points and you're through! For exact indication of displacement, the sensitivity constant** for the transducer must be entered.

Scale Mode

For the LVDT in use, key in two points of the expected motion in units of displacement and the corresponding desired output voltages, plus the sensitivity constant** of the transducer. That's it.

Gain Mode

Key in the desired conditioner gain. The analog output voltage will equal the input voltage (from the transducer) times this gain. This is the conventional operating mode of existing LVDT conditioners. The Model 451 front panel will display distance if the sensitivity constant** of the transducer has been entered as well as the corresponding output voltage. If desired, an autozero can be commanded at any time.

**The sensitivity constant of an LVDT, usually supplied by the manufacturer, is a factor linking excitation voltage and output voltage change to displacement. It is normally expressed in mV output per volt of excitation voltage per mil of displacement. For RVDT's, the displacement is normally in degrees. This constant can be accurately measured using the Model 451.

OTHER FUNCTIONS

Autozero

At any time, an autozero can be commanded to zero the output voltage for a new reference point. A manual mode allows an adjustable output offset to be entered. The user can view on the display either the amount of the offset or the amount of the offset including signal. When a zero offset is in use, the amount of the offset can be displayed.

Filter

Four filter positions are available to reduce output voltage noise while allowing maximum operating bandwidth. The filter positions are 1, 10, and 100 Hz plus wide band (approximately 250 Hz).

Excitation

Five excitation frequencies, 400, 1000, 2,500, 5,000, and 10,000 Hz and two voltage levels of 1.0 and 3.0 volts ac rms may be selected.

Calibration

When using the CAL function, an internally generated signal produces a precision voltage output from -10 volts to +10 volts selectable in 0.01-volt steps. Also displayed is the corresponding displacement in millimeters, milli-inches, or degrees.

Alignment

The Model 451 includes extensive self-calibration capabilities that allow full calibration of the instrument using only two resistive dividers (available from Ectron) and a digital voltmeter. (See Note 3 to Specifications)

Sensitivity Constant

Separate sensitivity constants are retained for each of the three operating modes. When units are changed between mil's and mm's the constant is converted to the proper numeric value. No conversion is made when going to the degrees units of measure. Allowable values of this constant using the Model 451 are:

Unit	Range
Mil	0.05 to 10.00 (mV/V/mil) default value is 0.300
mm	1.9685 to 393.70 (mV/V/mm) default value is 11.00
Deg	1.000 to 999.9 (mV/V/deg) default value is 11.00

Measuring the LVDT or RVDT Sensitivity Constant

It is necessary to know the sensitivity of the transducer (usually in terms of mV out per mil of displacement per volt of excitation) for an accurate displacement indication on the Model 451 display.

The sensitivity constant for an LVDT or RVDT transducer can be accurately measured using the Model 451. The procedure requires only that an accurate means of measuring displacement and output voltage be available. For example, for an LVDT, a suitable micrometer and a DVM could be used to make this measurement. When determining sensitivity this way, a higher degree of accuracy in subsequent LVDT measurements will be obtained because the conditioner will then be closely matched to the transducer.

The screens below show the setup procedure for both the example and scale modes

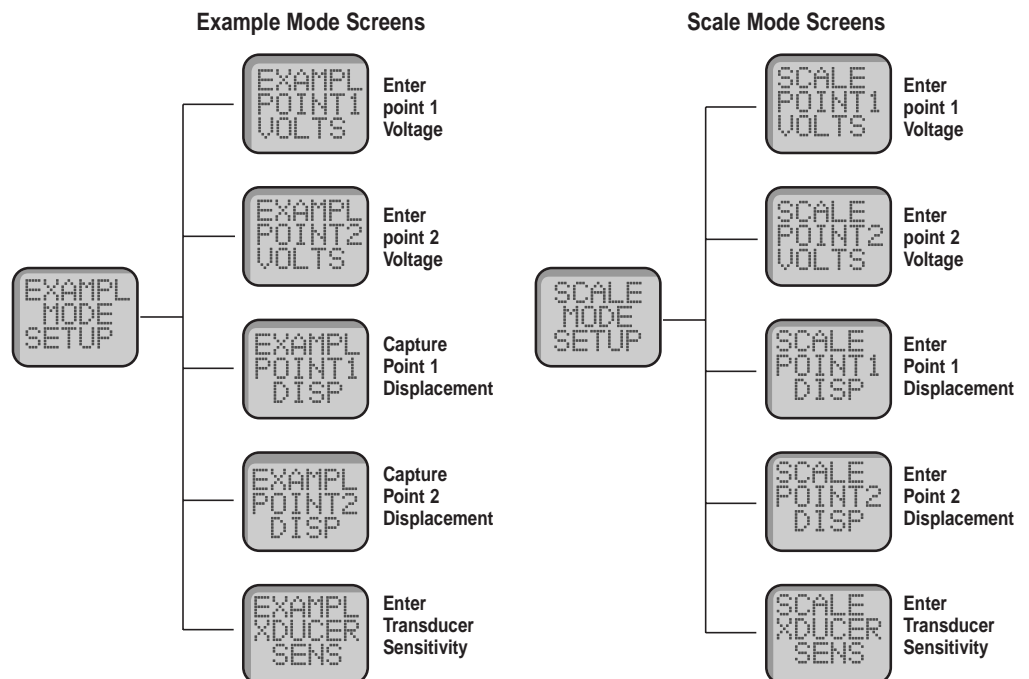

DISPLAY SCREENS

Operating:

During normal operation, the front panel display alternates between the input displacement (shown in mils, mm or degrees) and the output voltage. If desired, the input or output only may be displayed.

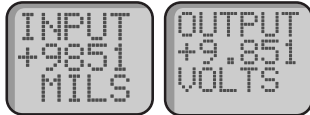

Function Selection

Each of the many functions is supported by a series of screen prompts. These functions include:

- Gain Mode Setup
- Example Mode Setup
- Scale Mode Setup
- Auto Zero
- Zero Setup (see Note 1)
- Filter Setup
- Calibrate (see Note 2)
- Excitation Setup
- Units Setup (mils, mm, degrees)
- Alignment (see Note 3)
- Viewing Angle

Examples of Setup Screens



Gain Mode: Screens for Gain Adjust and optional Transducer Sensitivity Constant (shown).



Example Mode: Screens for entering output voltage endpoints (Point 1 shown), for capturing transducer input at the endpoints, and for entering the optional Transducer Sensitivity Constant.



Scale Mode: Screens for entering output voltage endpoints, the input displacement endpoints (Point 2 shown), and for the Transducer Sensitivity Constant.



Filter Setup: Selecting low-pass filter cutoff at 1, 10 or 100 Hz, plus wide band (approx. 250 Hz). Similar screens set up excitation voltages and frequencies, measurement units, and calibration signals.

Alerts:

Screens that alert the user to setup or operating malfunctions include:

- Range Error
- Input Out of Range
- Zero Out of Range
- Memory Error
- Align Req'd

Controls:

The display/push button allows the operator to sequence through the various setup screens. The second switch has both push-button and rotary action. The push button moves the cursor to the digit to be changed and the rotary switch is used to change the selected digit. All operating parameters are set using these controls in conjunction with the display.

SPECIFICATIONS

INPUT

Configuration: Differential.

Input Impedance: $\pm 100\text{ K}\Omega \pm 5\%$ (each input).

Common Mode Voltage Range: $\pm 20\text{ V}$ dc or peak ac.

DYNAMIC RESPONSE

Gain Range: ± 1 to ± 300 (automatically set in example and scale modes).

Frequency Response: Selectable, 1, 10, and 100 Hz, and wide band (250 Hz typical).

Nonlinearity: 0.1% of full scale, maximum.

OUTPUT

Full Range: $\pm 10.5\text{ V}$ minimum.

Current: $\pm 10\text{ mA}$ minimum.

Impedance: $2.0\ \Omega$ Maximum.

Zero-offset Range: $\pm 10\text{ V}$.

Offset/Zero Control: There are three zeroing modes: autozero and two manual adjustment positions. (See Note 1)

EXCITATION

Voltage: 1 V or 3 V rms $\pm 1\%$.

Current: 30 mA rms minimum at 2500 Hz.

Frequency: Selectable: 400 Hz, 1.0, 2.5, 5.0, and 10 kHz.

Output Resistance: $1.0\ \Omega$ maximum at 2.5 kHz.

INPUT POWER

Voltage Range: 10.5 V to 32 V.

Current (nominal): 150 mA.

Over-voltage Protection: Up to +60 V for 15 seconds, +32 V and -50 V continuous.

CALIBRATION AND ALIGNMENT

Calibration: An internally generated calibration signal can be set from -10 V to +10 V in 0.01-V steps, and from -10000 to +10000 mils, from -254.0 to +254.0 mm and from -60.00 to +60.00 degrees. (See Note 2.)

Alignment: An extensive software-guided, self-calibration procedure is available for the complete alignment of the instrument. (See Note 3.)

Error Indicator: Front panel LED indicates errors. (See Note 4.)

ENVIRONMENT

EMI/RFI: Internal rfi filters are provided on all connector leads.

Operating Temperature Range: -25°C to $+71^{\circ}\text{C}$.

Storage Temperature: -40°C to $+80^{\circ}\text{C}$.

Altitude: No limit with adequate heat dissipation.

Static Acceleration Resistance: 200 m/s^2 (approximately 20 g), 11 ms in any plane.

Shock Resistance: 200 m/s^2 (approximately 20 g) 11 ms in any plane.

Vibration Resistance: 100 m/s^2 (approximately 10 g) in any plane.

DIMENSIONS

Height (panel): 60.2 mm (2.37 in).

Height (case): 50.8 mm (2.00 in).

Width: 28.4 mm (1.12 in).

Depth: 101.6 mm (4.00 in) plus controls and connector.

Weight: 255 g (9 oz) nominal.

Connector: DA-15P (mate DA-15S).

COMPATIBILITY

The Model 451 will operate in all standard Ectron enclosures designed for conditioner-amplifier Models 352, 418, T418, 428, and 441A.

NOTES

Note 1. Zero Controls: Several zeroing modes are available when using the Model 451's output zero circuit. Automatic zeroing can be commanded at any time which will bring the output to zero within 5 mV. In addition, manual zeroing allows the user to either view the amount of the offset voltage or to view the amount of the offset voltage plus output signal. The zero range available is from -10 V to +10 V in 0.01 V steps.

Note 2. Calibration: Since the calibration adjustment allows the output voltage to be set in 0.01 V steps from -10 V to +10 V with an accuracy of better than 0.1%, this output can be used to check linearity of the instrumentation following the Model 451. The output voltage can be varied also by varying the displacement reading while in the displacement part of the calibration mode.

Note 3. Alignment: The Model 451 includes extensive self-calibration capabilities that allow full alignment of the unit using only two resistive dividers (available from Ectron) and a digital voltmeter.

The output stages are aligned with the voltmeter by making two adjustments via the front panel controls. Similarly, the input stages are calibrated applying resistive dividers to the input and commanding the Model 451 to self-align. Once aligned, values are stored in nonvolatile memory.

Note 4. Error Indication: The Model 451 has a front-panel LED error indicator. This LED lights for three different classes of error: 1. A data-entry error. This type of error results from a front-panel entry that the hardware cannot support (such as gain beyond the range of the analog circuitry). 2. Output overload. This error results from a situation that produces an output outside of the ± 10.5 volt range. 3. Input overload. This error condition results from an input signal that is beyond the range of the unit, such as a large-scale input when a high gain is requested. In each case, the LCD displays a screen describing the error and the LED remains lit as long as the error persists.

Model 451 Application

Application of the Ectron Model 451 LVDT Conditioner using Example Mode

Suppose we wish to monitor the position of a suspension component of a vehicle with respect to another member of the vehicle. First we mount the LVDT where the desired motion will occur. With the Model 451 in example mode, position the

vehicle to one end of its expected motion and command a capture of "Point 1." Then, key in the desired analog output voltage for this point. Repeat this step for the other end of the expected motion, capture its position as "Point 2" and key in the desired voltage for this second point. For an accurate indication of displacement on the display,

key in the sensitivity constant of the transducer. The conditioner is now set up for this application. We can monitor both the displacement of the suspension component and the corresponding output voltage on the screen of the Model 451 while testing the vehicle.

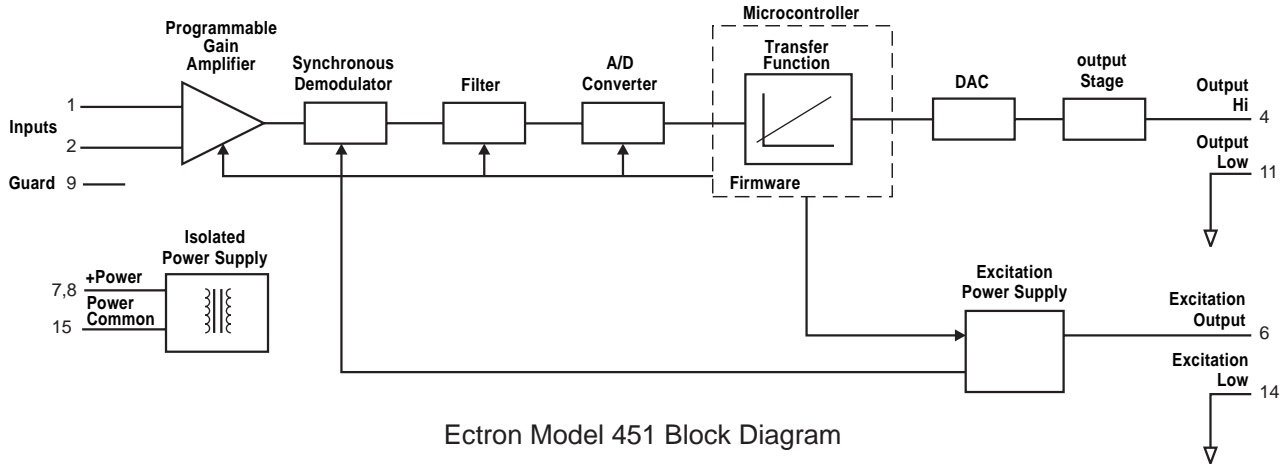

Model E408-6 Six-channel Portable Enclosure



Model 4001 Fourteen-channel Ruggedized Portable Enclosure

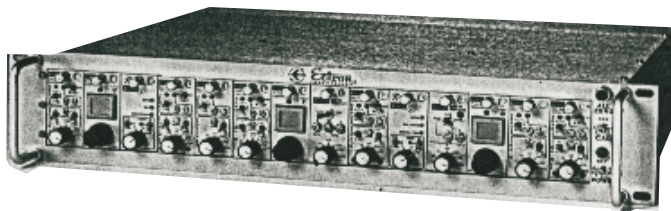

Model R408-14 Fourteen-channel Rack-mount Enclosure

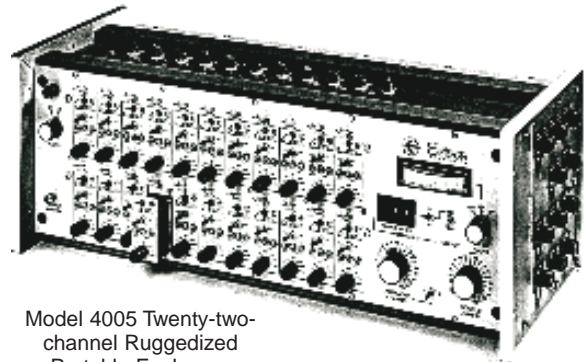

Model 4005 Twenty-two-channel Ruggedized Portable Enclosure

ENCLOSURES

COMPATIBILITY

The Model 451 will operate in all standard Ectron enclosures designed for Models 352, 418, T418, and 428 Amplifier/Conditioners and Model 441A F-V Converter. These include Models E408, R408, 4001, and 4005 enclosures.



Ectron
CORPORATION®

8159 Engineer Road, San Diego, CA 92111
Telephone: (858) 278-0600 • Fax: 858-278-0372
E-mail: sales@ectron.com
Visit our Web site: <http://www.ectron.com>

Call Toll Free (800) 732-8159

Copyright ©1999 Ectron Corporation. All rights reserved.