

Model 751 PRECISION WIDE BAND DIFFERENTIAL DC AMPLIFIER

PERFORMANCE HIGHLIGHTS

- 300 V Common-mode Voltage (CMV)
- 140 dB Common-mode Rejection
- 0.005% Linearity
- True 0.01% Gain Accuracy
- 0.003%/°C Gain Stability
- Dc to 100 kHz Bandwidth
- < 200 pF Shunt Capacity
- 0.4 μ V/°C Zero Stability

FEATURES

- Gains from $\times 0.01$ to $\times 2500$
- Selectable 3-pole Active Filter
- Dual Outputs, Wideband and Filtered
- Individually Ac Powered
- 12 Amplifiers per 5 1/4" \times 19" Enclosure
- Low Power Consumption, Low Parts Count
- Minimum Internal Wiring



Model 751ELN with
M563 Single-channel Bench Mount



Model E712-3-12 Rack-mount Enclosure
with Model 751ELN Amplifiers



Model 751ELN

GENERAL DESCRIPTION

The Ectron Model 751 is a precision wideband dc amplifier, featuring true differential input circuits, high common-mode-voltage rating, and excellent stability and linearity. The basic amplifier is a direct-coupled design providing high input impedance, excellent common-mode-rejection and low output noise. Each amplifier has its own independent internal power supply which operates directly from standard 50 to 400 Hz power lines. Amplifier gain is front-panel selectable from $\times 0.01$ to $\times 1000$ with gain accuracy of $\pm 0.01\%$. Amplifier bandwidth is front panel selectable with 3-pole low pass filters having -3 dB cut-offs of 1 Hz, 10 Hz, 100 Hz, 1 kHz, and 10 kHz plus a wide band setting. Full bandwidth exceeds 100 kHz.

LINEARITY AND GAIN ACCURACY

Since there are no modulators, demodulators, or transformers in the signal or feedback paths, it is possible to operate the Model 751 amplifier with very high loop gains. This results in improved linearity (0.005%) and permits gain options with $\pm 0.01\%$ accuracy without degradation on the higher gains. Competitive units often specify $\pm 0.01\% \pm 3 \mu\text{V RTI}$, which is in fact $\pm 0.04\%$ at a gain of 1000. The 0.01% gain specification of the Model 751 amplifier applies at all gains, and there are no tweaks on individual gain ranges.

SIMPLIFIED DESIGN

The internal circuitry uses both discrete components and integrated circuits, providing state-of-the-art performance while keeping cost and complexity to a minimum. The unit's low power consumption reduces warm-up time and component aging due to internally generated temperature rise.

The simplified circuitry contributes to an uncrowded mechanical design allowing up to 12 amplifiers to be installed in a single 5.25-inch-high enclosure. Although small, the amplifiers include selectable bandwidth and two outputs with a combined output capability of 110 mA.

ISOLATION

Model 751 amplifiers vary from most high-CMV amplifiers in that they do not have complex modulator-demodulator circuits. Operation with high common-mode voltages (CMV) is achieved by floating the input amplifier at the common-mode voltage and then attenuating the output to a CMV level of 10 volts or less. The CMV is then rejected by a precision, direct-coupled, differential amplifier.

The amplifier contains a high-impedance common-mode amplifier (CMA), which senses the CMV level from the signal input terminals.

The guard-to-ground impedance is $56 \text{ M}\Omega$ in parallel with $0.001 \mu\text{F}$.

As illustrated in Figures 1 and 2, there are two ways to handle the guard in a direct-coupled instrumentation amplifier.

The amplifier in Figure 1 ties the guard directly to the preamplifier section and, therefore, depends on the external shield connection to drive the power supplies and circuitry of this section of the amplifier. This design approach has been termed a guard-dragger amplifier.

Figure 2 illustrates the superior system which uses a common-mode amplifier (CMA) to drive the preamplifier. Used in the Model 751 amplifier, this approach eliminates much of the loading problem on the external shield. Also, since in the Ectron design the CMA signal is actually obtained from the two signal leads through a high-impedance divider, the amplifier will operate without the guard connected with little change in performance.

In the Model 751 amplifier, the load resistance between guard and output common is over $50 \text{ M}\Omega$. For the typical guard-dragger amplifier this resistance is approximately $500 \text{ k}\Omega$. At a common-mode voltage of 300 V this requires a load current of 0.6 mA or 0.18 watts. Although loading the external shield circuit to this extent can cause application problems, an even greater problem is that current flowing into the guard of the guard-dragger amplifier must flow through the signal-carrying resistors that connect the preamplifier to the output amplifier. As a result, high-frequency CM signals that would be filtered out in the Model 751 amplifier will be mixed with the desired signal in these interconnecting resistors. Consequently, high-frequency common-mode rejection (CMR) is usually poor in the guard-dragger amplifier. (CMR for the Model 751 at $\times 1000$ gain and 60 Hz is 124 dB and at 10 kHz is 74 dB.) Guard-dragger amplifiers do not specify CMR above 60 Hz.

DYNAMIC RESPONSE

The Model 751 amplifiers have wide bandwidth, fast settling time and fast overload recovery. Due to the low input capacitance, the specifications in these areas are typically met with source impedances considerably greater than the 1000 ohms listed in the specifications. Another inherent characteristic which enhances speed and accuracy in many applications is the low capacitance between input guard and output and power-line commons.

Although this capacitance has a moderate effect on several types of measurements, the most common application involves two-wire input scanning. In these applications, the guard is connected to one of the input lines at the scanner and its capacitance to ground can then affect settling time and accuracy. The error factor occurs when the guard capacitance partially discharges a "flying capacitor" scanner or filters on the input side of a conventional scanner. The guard-to-ground capacitance of the standard amplifier is less than 1000 pF.

GAIN CONTROL

The Model 751 is provided with switch-selectable fixed gain steps and a vernier gain control with a multiplying range of 1:1 to 2.5:1. Option "N" adds a front-panel-mounted 100:1 input divider switch, thereby providing continuous gain from $\times 0.01$ to $\times 1000$ or $\times 2500$ with vernier gain in. The Model 751 is provided with a front-panel switch to deactivate the vernier gain when highest accuracy and stability is required.

ADDITIONAL FEATURES

A "0" gain position is provided at each end of the gain switch to aid in zeroing the amplifier. When the gain switch is placed in a "0" position, the amplifier input is disconnected from the input signal, shorted, and the amplifier gain is set to a gain of $\times 1$ or $\times 1000$ as indicated on the front-panel gain-switch nomenclature.

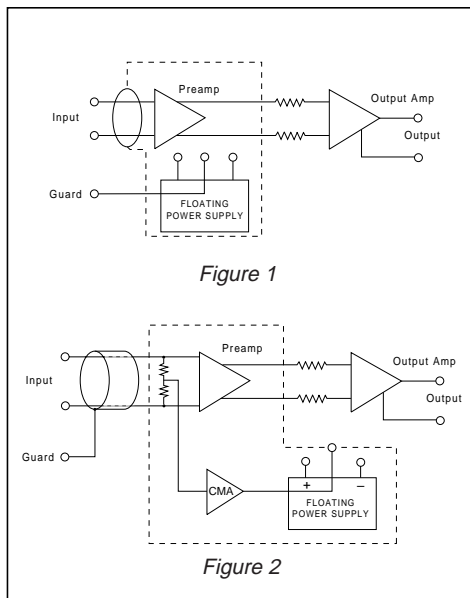

Figure 1

Figure 2

SPECIFICATIONS

(Unless noted, all specifications apply at 25°C after 30 minutes warm-up with 0 to 1000 Ω source in any unbalance)

INPUT

Configuration: differential, direct coupled, isolated from output and ground; may be used inverting, noninverting, differential or single-ended. Connection of guard to input source provides adequate return path.

Impedance	20 MΩ, parallel with 200 pF
Source Current, Gain < 10	±30 nA at 25°C
Source Current, Gain > 10	±1 nA at 25°C
Impedance, Option N switch in	1 MΩ, parallel with 200 pF
Max. Input Overload	±30 V without damage, ±300 V with Option N switch in
Guard Impedance to Common	56 MΩ parallel with 1000 pF

ZERO

Front-panel Control	±100 μV RTI* range, nominal 0.01% full scale resolution
Stability	
Voltage	±2 μV RTI ±0.25 mV RTO* for 200 hrs.
Source Current	±1 nA for 200 hrs.
Temperature Coefficient	
Voltage	±0.4 μV/°C RTI ±0.2 mV/°C RTO
Source Current	±0.5 nA/°C

GAIN (Option L plus Option N)

Gain Steps	Switch selectable gains of 0, 1, 2, 5, 10, 20, 50, 100, 200, 500, 1000. With 100:1 input divider gains become 0, 0.01, 0.02, 0.05, 0.1, 0.2, 0.5, 1, 2, 5, 10
Gain Step Accuracy	±0.01%
Front-panel Vernier	Multiplier ×1 to ×2.5
Stability, Time (Vernier Out)	±0.01% for 6 months
Stability, Temperature (Vernier Out)	±.003%/°C

DYNAMIC RESPONSE

Bandwidth	< 3 dB down at 100 kHz
Settling Time	
Output #1 (Wideband)	30 μs to ±0.1% of step value
Output #2 (Filtered)	100 μs + 1.8 sec/f _{co} to ±0.1% of step value
Overload Recovery, Output #1, from 1000% F.S. but < 30 V	50 μs to ±0.1% of F.S.
Slewing Rate, Output #1	
Balanced, Differential Signal	3.2 V/μs
Fully Unbalanced Signal	3.2 V/μs, gains above 20 1.5 V/μs, gains 1 thru 20
Linearity	
Dc	±0.005% of full scale
Dc to 2 kHz	±0.01% of full scale

NOISE

Definition: Noise specifications apply when measured with a bandpass system with first-order rolloffs adjusted for -3 dB at the upper and lower frequencies listed.

Peak, 3 sigma	
0.1 Hz to 10 Hz	0.75 μV RTI + 0.1 mV RTO
0.1 Hz to 100 Hz	2 μV RTI + 0.25 mV RTO
0.1 Hz to 1 kHz	4 μV RTI + 0.5 mV RTO
0.1 Hz to 10 kHz	8 μV RTI + 1 mV RTO
RMS	
0.1 Hz to 10 kHz	2 μV RTI + 0.5 mV RTO
0.1 Hz to 100 kHz	5 μV RTI + 2 mV RTO

FILTER (Option E)

Filter Characteristics	3-pole Bessel
Cutoff Frequencies (f_{co} -3 dB)	Switch selectable: 1 Hz, 10 Hz, 100 Hz, 1 kHz, 10 kHz, W.B. (Filter Out)

COMMON MODE

Common-mode Voltage (CMV)	±300 V dc or peak ac
Maximum CMV Rise Time	No limit within CMV rating
Common Mode Rejection	80 dB plus gain in dB at dc 124 dB or 64 dB plus gain in dB, whichever is lower
Dc to 60 Hz, 1 kΩ unbal.	74dB or 14 dB plus gain in dB, whichever is lower
Dc to 10 kHz, 350 Ω unbal.	

POWER, DIMENSIONS, ENVIRONMENT

Power Requirements	105 to 125 V ac, 50 to 400 Hz, 8 watts nominal. 220 V ac, 240 V ac, and 100 V ac available for export
Dimensions	5.25" high × 1.4" wide × 16" deep 12 units per 5 ¹ / ₄ × 19" enclosure
Operating Temperature	0 to 55°C
Relative Humidity	Up to 90% RH at 40°C
Storage Temperature	-25°C to +70°C

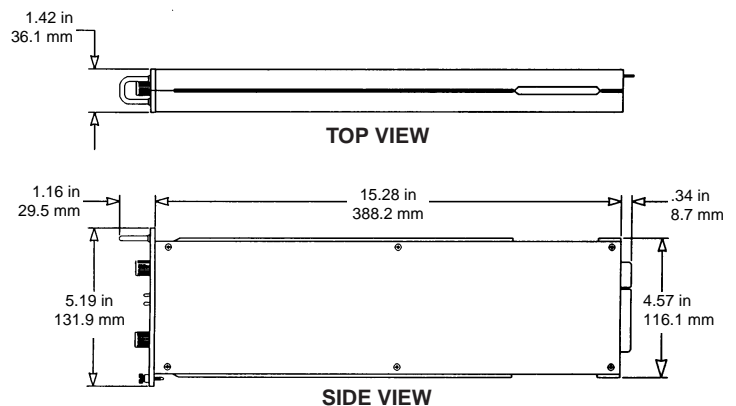

* RTI is Referred To Input; RTO is Referred To Output

OUTPUTS

	Output #1 (Wideband)	Output #2 (Filtered Output)
Voltage	±10 V dc or peak ac	±10 V dc or peak ac
Current	±100 mA (110 mA max, #1 and #2)	±100 mA (110 mA max, #1 and #2)
Output Impedance	0.1 Ω at dc	0.1 Ω at dc
Nominal Overrange	20%	20%
Capacitance Loading	> 1.0 μF without instability	> 1.0 μF without instability
Output Isolation	No load to full load on Output #2 affects Output #1 less than 0.01%	No load to full load on Output #1 affects Output #2 less than 0.03%
Short circuit	No damage with sustained short circuit on either or both outputs	

ENCLOSURES

Model E712-1-12 Rack-mount Enclosure accommodates up to twelve (12) amplifiers. System input and output cables are soldered directly to the amplifier card connectors in the rear of the enclosure. Ac power cord and power wiring to all amplifiers is included. Enclosure dimensions are 5.25" high, 19" wide by 20" deep.

Model E712-3-12 Rack-mounting Enclosures are identical to the E712-1-12 except that rear panel connectors, with mates, are provided for each amplifier input, and two larger connectors, one for all twelve wideband outputs and one for all twelve filtered outputs, are also included.

The standard input connectors are MS3102A-14S-7P with MS3106A-14S-7S mates. Both output connectors are MS3102A-28-12P with MS3016A-28-12S mates. All internal wiring from the amplifier card connectors to the rear panel connectors is included as is ac power cord and power wiring. Enclosure dimensions are 5.25" high, 19" wide by 20" deep plus connectors.

Different input/output connectors are available on special order. Note photo below for Model E712-3-12-M1041. Inputs are individual XLR-3-32; mating connectors supplied are XLR-3-11. Outputs are individual BNC.

ACCESSORIES

Model 720 Cable Assembly provides all input, output and power cables for bench operation of a single amplifier.

Option M563 Mount provides a bench mount for a single amplifier.

P/N **750-504-01** Single-channel filler panel for E712 Enclosure.
P/N **750-504-12** Four-channel filler panel for E712 Enclosure.

Specifications subject to change without notice.

ORDERING INFORMATION

Model 751

OPTIONS - Required

Filter

E Selectable, 6-step, 100 mA

Gain

L Continuous, $\times 1$ to $\times 2500$, 0.01%

N 100:1 Input Divider

ENCLOSURES AND ACCESSORIES FOR 750A SERIES AMPLIFIERS

E712-1-12 Enclosure for direct-soldered input/output cabling

E712-3-12 Enclosure with input/output wiring and rear panel connectors with mates.

750-504-01 Single-channel Filler Panel

750-504-12 Four-channel Filler Panel

M563 Single-unit Mount

720 Single-unit Input/Output Cable Assembly

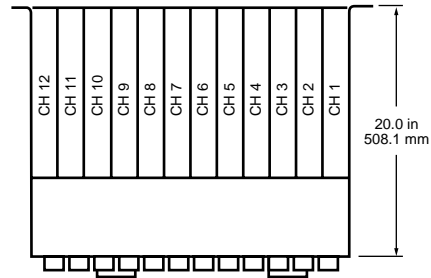

TOP VIEW

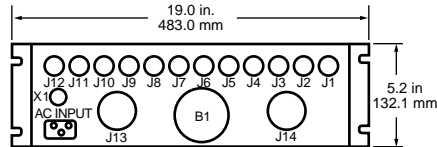

REAR VIEW

Model E712 Enclosure Dimensions

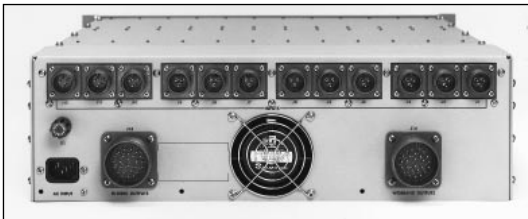

Rear view of Model E712-3-12 Enclosure



Rear view of Model E712-3-12-M1041



Model 720 Single Unit Cable Assembly



For quick response, call
1-800-732-8159

8159 Engineer Road
San Diego, CA 92111
Telephone: (858) 278-0600
FAX: 858-278-0372
E-mail: sales@ectron.com
http: //www.ectron.com