

MODEL 428

DIFFERENTIAL DC AMPLIFIER AND SIGNAL CONDITIONER



Standard Model 428



With Option O



With Options L, O



With Options G, L, and O

See Dimensions in Specification Section

RUGGED APPLICATIONS

- Vehicle Crash Testing
- Helicopters
- Flight Testing
- Shipboard
- Rocketry
- Automobiles

ENVIRONMENTAL RATINGS

- 100 g Shock
- 20 g Continuous Vibration
- -55°C to $+100^{\circ}\text{C}$
- 90% Relative Humidity
- Thermal Shock Resistant

PERFORMANCE HIGHLIGHTS

- True Differential Amplifiers
- $0.5 \mu\text{V}/^{\circ}\text{C}$ Stability
- Bridge Excitation
- Autozero
- Zero Suppression
- Dual Gain Ranges

Ectron Corporation has been building small, rugged, reliable instrumentation amplifiers for over 25 years. Primary emphasis has always been reliability and accuracy under poor environmental operating conditions. Over the years the Ectron 400 Series has been the established leader in both the auto and aerospace industries for on-board vehicle test.

Because of recent technological advances, including surface-mount construction, Ectron embarked on a major design effort to further improve this product. This has now culminated in the development of the NEW Model 428.

Retaining the basic form and design of the Model 418, including chopper stabilization and transformer isolation, the NEW Model 428 is a direct replacement for most Model 418's including operation in most existing Model R418, 4001, and 4005 enclosures.

The NEW Model 428, however, offers improved performance and operator conveniences such as increased input impedance, increased signal bandwidth, dual gain ranges, and front-panel-selectable excitation as standard features. Also standard is EMI/RFI filtering (option I in the Model 418) and operation from any dc-power voltage from 10.5 to 32 volts with power consumption reduced by almost 50% over that of the Model 418.

GENERAL DESCRIPTION

The Model 428 is a true differential amplifier with transformer isolation between input, output, and the power source. An internal dc-dc converter provides bipolar voltages for the internal circuitry while accepting power from a single external dc power supply or battery. In addition to the high-performance amplifier, the unit includes an integral excitation power supply. Transformer coupling contributes to high common-mode rejection, and the chopper design results in superior zero stability, both short term and long term.

RUGGED CONSTRUCTION

Ectron 400 Series Differential DC Amplifiers and Signal Conditioners are designed for reliable operation in the most severe and dramatically changing environments. The amplifiers have produced uninterrupted data while subjected to the vibration of helicopters, the impact of rocket test sleds, the abrupt temperature and altitude shifts of supersonic aircraft, and the general abuse encountered on automotive proving grounds.

The amplifiers are housed in a steel casing and fully protected from moisture, including condensation. One-hundred-percent factory testing assures normal operation over the ambient temperature range of -25°C to $+71^{\circ}\text{C}$, with extremes of -55°C to $+100^{\circ}\text{C}$ certified on special order.

ISOLATION

True ohmic isolation is provided between input, output, and power source by means of transformer coupling (see block diagram, Fig. 1). This results in excellent common-mode rejection and the ability to operate with common-mode potentials of 100 volts dc or peak ac.

Figure 1 shows operation from a single dc-power source. For operation in conventional, industrial, and laboratory applications, the R418 series rack mount enclosures may be optionally equipped with heavy-duty 115 volts ac (or 220 volts ac) power supplies to provide dc power to all amplifiers within the enclosure.

TEMPERATURE STABILITY

Ectron 400 Series Amplifiers have an inherent temperature stability that does not require delicate balancing of offset-producing components.

Direct-coupled amplifiers, by contrast, depend on temperature-compensation circuits to balance the characteristics of transistor pairs. The technique is reasonably effective for gradual temperature changes, but does not provide an effective solution to the problems that occur when the operating environment is changing rapidly.

Temperature shifts of this type can occur during warmup, with changes in altitude, or even when a single amplifier is removed from the rack and there is a resulting change in the airflow through the system.

The recording below (Fig. 2) compares the zero stability of a 400 Series amplifier with a direct-coupled amplifier when the temperature is changed abruptly from 23°C to 0°C . This illustrates why direct-coupled amplifiers do not include "dynamic zero stability" as a specification item.

LOW 1/F NOISE

In very low-level high-resolution systems, the noise generated by the amplifier becomes a significant factor in determining the accuracy that can be achieved. In narrow-band systems, the use of low-pass filtering is helpful, but its effectiveness in

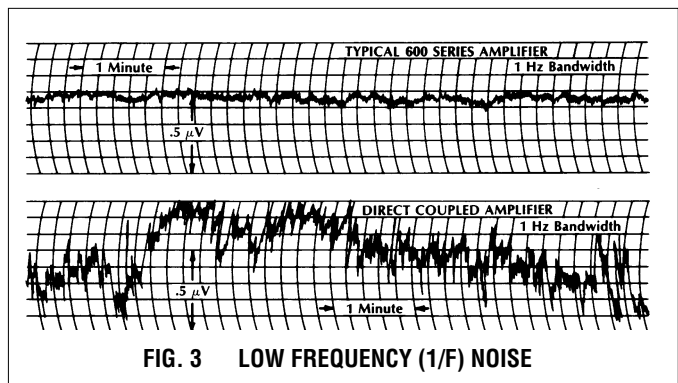
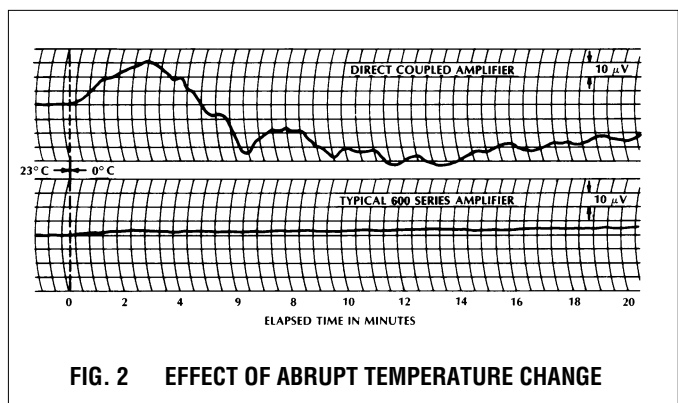
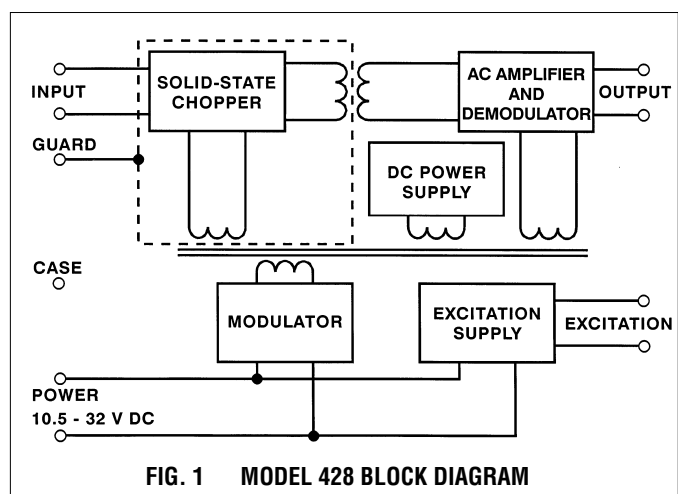

amplifiers is limited by a low-frequency component referred to as 1/F noise. Well-designed chopper amplifiers such as the 400 Series are significantly superior in this area. Usable sensitivity extends to well under one microvolt.

A comparative recording of the 400 Series and a direct-coupled amplifier is shown in Figure 3. Since very-low-frequency phenomena is illustrated, the chart speed is slow, and both outputs are prefiltered with a low-pass 1 Hz filter.

EMI/RFI

All dc amplifiers produce some error when subjected to conducted or radiated rf signals of sufficient magnitude. If this error appears in the form of spikes or an ac waveform at the output, it is readily recognized. Unfortunately, the error is often a dc offset which changes in magnitude as the level or frequency of the interference signal changes. This is because the signals are internally rectified by the amplifiers.

In a direct-coupled amplifier, any dc level produced by this rectification is amplified and appears as an error signal at the output. On the other hand, a chopper amplifier will not necessarily do this. Referring to the 400 Series block diagram note that the design incorporates an "ac" amplifier which is capacitively coupled to the output demodulator. This means that RFI can produce a dc level shift in the amplifier without affecting the output.

Although the standard 400 Series can outperform most other types of amplifiers in side-by-side comparisons, it is not totally

immune to EMI/RFI. Therefore, special models (or systems) can be provided that include supplementary protection. When so equipped, the 400 Series amplifiers have demonstrated their ability to function properly in rf environments that cause other amplifiers to "lock up" at full-scale output.

MODEL 428

The standard, without options, Model 428 operates from dc power within the range of 10.5 to 32 volts. All units include EMI/RFI protection and front-panel toggle switch selection of a constant-voltage excitation of 5V, 7V, or 10 volts. Another front-panel toggle switch selects one of the two gain step ranges i.e. 10, 20, 50, 100, 200, 500, 1000 or 0.1, 0.2, 0.5, 1, 2, 5, 10. Additionally, ± 40 mV of input zero suppression is provided by front-panel screwdriver multiturn coarse and fine zero controls. Amplifier output is ± 10 Volts.

MODEL 428 OPTIONS

Option B changes the amplifier output capability from ± 10 Volts to a limited 0 to +5 Volt output.

Option G changes the dual gain-step ranges to binary, i.e. 16, 32, 64, 128, 256, 512, 1024 and 0.1, 0.2, 0.4, 0.8, 1.6, 3.2, 6.4.

Option L adds latched front-panel LED indication of output overvoltage with a front-panel reset switch.

Option O adds autozero with front-panel manual control and remote control capability.

SPECIFICATIONS

The following specifications are the maximum deviation from the ideal permitted in this Ectron instrument. All specifications apply with a fixed source resistance of 0 to 500 ohms in any unbalance over the temperature range of -25°C to $+71^{\circ}\text{C}$, unless otherwise stated. RTI means referred to input; RTO, referred to output.

INPUT CHARACTERISTICS

Configuration: True differential with guard, transformer isolated. Can operate from isolated source. May be used inverting, noninverting, differential or single-ended.

Impedance: ≥ 1 M Ω ; high gain range.
100 k Ω $\pm 5\%$; low gain range.

VOLTAGE RANGE

Normal-mode voltage (without damage):
 ± 17 V dc or peak ac maximum, high gain range.
 ± 150 V dc or peak ac maximum, low gain range.

Common-mode voltage (operating):
 ± 100 V dc or peak ac maximum.

Common-mode rejection (CMR):
 ≥ 140 dB, dc, 100- Ω unbalance.
 ≥ 120 dB, ac, 60 Hz, balanced.
 ≥ 100 dB, ac, 60 Hz, 100- Ω unbalance.
 ≥ 100 dB, ac, 400 Hz, balanced.
 ≥ 90 dB, ac, 400 Hz, 100- Ω unbalance.

Noise (Peak, 3 Sigma)
0.1 Hz - 10 Hz, ≤ 1 μV RTI 1 mV RTO.
0.1 Hz - 300 kHz, ≤ 5 μV RTI + 2.5 mV RTO.

GAIN

Decimal (Standard) Seven front-panel switch-selectable calibrated gain steps of 10, 20, 50, 100, 200, 500, and 1000 plus a switch selectable 100:1 input divider and a vernier gain, $< \times 1$ to $> \times 2.5$, with in-out switch.

Binary (Option G) Seven front-panel switch-selectable calibrated gain steps of 16, 32, 64, 128, 256, 512, and 1024 plus a switch selectable 160:1 input divider and a vernier gain, $< \times 1$ to $> \times 2.5$, with in-out switch.

Accuracy: Steps $\pm 0.2\%$, Input divider $\pm 0.1\%$.

Stability: Time (200 hours) $\pm 0.02\%$,
Temperature (steps) $\pm 0.005\%/^{\circ}\text{C}$, (Input divider) $\pm 0.004\%/^{\circ}\text{C}$.

Zero Shift with Gain Change: ± 10 mV RTO maximum.

ZERO

Stability:
Time (200 hours): ± 4 μV RTI ± 200 μV RTO.
Temperature: ± 1 $\mu\text{V}/^{\circ}\text{C}$ RTI ± 50 $\mu\text{V}/^{\circ}\text{C}$ RTO.
Dynamic temperature (20 $^{\circ}$ step change):
 ± 8 μV RTI ± 400 μV RTO.

Adjustment Range (Affects amplifier input):
High gain range: ± 40 mV RTI.
Low gain range: Decimal gain ± 4 V RTI,
Binary gain ± 6.4 V RTI.

Controls:
Coarse: 20-turn potentiometer with a nominal resolution of better than 150 μV RTI
Fine: 20-turn potentiometer with a nominal resolution of better than 10 μV RTI.

DYNAMIC RESPONSE

Frequency Response (5-pole Butterworth):
Dc to 3 kHz $\pm 5\%$, -3 ± 1 dB at 5 kHz.

Linearity: $\pm 0.04\%$ of full-scale output maximum deviation from the best straight line thru zero.

Overload Recovery: ≤ 5 ms recovery from a "10 x full scale" input (up to the maximum normal-mode voltage allowed) to within $\pm 0.1\%$ of the rated full-scale output.

Autozero (Option O):
Capture Range: ± 10 mV RTI.
Final Value: ± 20 μV RTI ± 10 mV RTO.
Temperature Stability: ± 0.5 $\mu\text{V}/^{\circ}\text{C}$ RTI.
Resolution: 20 μV RTI.

OUTPUT CHARACTERISTICS

Isolation: The output is transformer isolated from the input and power supply. The output-to-case voltage can be up to ± 50 V dc or peak ac. The capacitance from output low to case and to power common is 0.22. μF .

Linear Range:

Voltage:
Standard: From -10 V to +10 V, dc or peak ac.
Option B: From 0 V to +5 V (-0.8 V to +6 V maximum).

Current: 10 mA. The maximum fault current is dependent on temperature. It is approximately 25 mA at 25°C and varies inversely with temperature.

Impedance: ≤ 1 Ω (dc), ≤ 2 Ω (at 5 kHz).

Capacitive Load: The output will be stable under all normal signal conditions with a capacitive load of up to 0.02 μF .

Protection: No damage will occur with a continuous short on the output.

SPECIFICATIONS (Continued from previous page)

LIMIT DETECTOR (Option L)

If the amplifier output exceeds the rated full-scale output voltage, a front-panel LED will energize and stay on until manually turned off with the front-panel RESET pushbutton.

Limits: Standard: $\pm 10.3\text{ V} \pm 0.3\text{ V}$
Option B: $+5.2\text{ V} \pm 0.2\text{ V}$

TRANSDUCER EXCITATION

Voltages Available:

Three front-panel-selectable voltages of 5, 7, and 10 V dc (other voltages optional).

Accuracy: $\pm 1\%$.

Output Current: $\geq 100\text{ mA}$ with power supply voltage from 10.5 to 15 V dc, then derated linearly to 50 mA at 32 V dc.

Current Limit: Output current limit is 120 mA nominal with $< 10\%$ change over full temperature range. No damage from short circuit.

Regulation:

Load: $\pm 0.1\%$ no load to full load.
Line: $\pm 0.05\%$ for a 30% line variation.

Noise: 1 mV rms, 0.1 Hz to 1 MHz.

Temperature Coefficient: $\pm 0.005\%/^{\circ}\text{C}$.

Isolation: Excitation low is connected directly to input-power common.

INPUT POWER

Range: 10.5 to 32 V dc.

Overvoltage Protection: up to +60 V for 15 s maximum. Reverse-voltage protected to -50 V continuous.

Current (nominal):

80 mA plus excitation load plus 1.2 times amplifier load. Maximum 280 mA.

ENVIRONMENT

Storage Temperature: -60°C to $+125^{\circ}\text{C}$.

Operating Temperature: -25°C to $+71^{\circ}\text{C}$.

Relative Humidity: 90% noncondensing.

Altitude: No limit with adequate heat dissipation.

Static Acceleration: 100 g (20 g when installed in an Ectron enclosure).

Shock (6 ms sawtooth):

100 g (20 g when installed in an Ectron enclosure).

Vibration:

0.12" DA (5 to 55 Hz).
20 g (55 to 2 kHz).

EMI/RFI Protection: Filters are provided in all connector leads.

DIMENSIONS

Height (panel)	Height (case)	Width	Depth
60.2mm (2.37")	50.8 mm (2")	28 mm (1.12")	101.6 mm (4")

Weight: 255 g (9 oz) nominal.

Connector: DA-15P (Mate, DA-15S).

ENCLOSURES

Model E408-6

The Model E408-6 Portable Enclosure, designed for up to 6 amplifiers, is approximately 3.5"H x 10"W x 11"D and includes rubber mounting feet and handles. Rear panel mounted individual input connectors (PT02A-10-6S, with mates) and output connectors (BNC) are provided. The top cover removes to provide access to a bridge completion assembly with terminals for CAL and completion resistors. Front panel controls for ALL Autozero and ALL Shunt CAL are provided. The enclosure is 115 V ac-powered with provision for dc power input.

Model R408-14

The Model R408-14 Rack Mount enclosure holds up to 14 amplifiers in 3.5" of vertical panel space of a 19" RETMA rack width, 16" deep. Rear panel mounted individual input connectors (PT02A-10-6S, with mates) and individual output connectors (BNC) are provided. The rear section of the top cover removes to provide access to a bridge completion assembly with terminals for CAL and bridge completion resistors. Front panel controls for ALL autozero and ALL Shunt CAL are provided. The enclosure is 115 V ac-powered with provision for dc power input.

Model 4001, Signal Conditioning System

The typical 4000 Series signal conditioning system is designed for airborne, vehicular or marine service involving moderate g forces. It accommodates up to 14 amplifiers and includes a monitor meter and individual CAL switches on each channel. The channel selector switch chooses one of the 14 channels, and the switch associated with the monitor meter permits reading the excitation voltage, or the amplifier's output on one of three full scale ranges: 100 mV, 1 V or 10 V.

Individual input connectors are provided for each channel on the right side of the system, normally

WK-5 twist-lock type connectors, with mates. Individual XLR series output connectors are provided across the top, as are replaceable calibration resistors for each channel. The system comes equipped with handle and detachable covers to prevent damage during transit. Nominal system dimensions are 14" x 8" x 8". Special versions with additional features and/or different connectors are available. Please consult the factory for your specific requirements.

Model 4005

This system is similar to the Model 4001 except that it is designed for 22 amplifiers. Other features include a built-in output reference supply. Standard input connectors are PT02A-10-6S and output connectors are BNC. Nominal system dimensions are 22" x 8" x 8". Special versions with additional features and/or different connectors are available. Please consult the factory for your specific requirements.



Model E408-6



Model R408-14

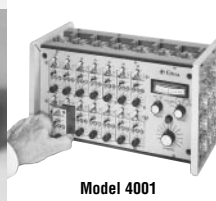

Model 4001



Model 4005

ORDERING INFORMATION

Model 428 Standard Amplifier/Conditioner.

Option B Output 0 to 5 V.

Option G Binary Gain.

Option L Output limit detector & reset.

Option O Autozero.

Specifications subject to change without notice.



For quick response, call
1-800-732-8159

8159 Engineer Road
San Diego, CA 92111
Telephone: (858) 278-0600
FAX: 858-278-0372
E-mail: sales@ectron.com
http://www.ectron.com